

SLG® + SP MDQ503 Mobile Containerized Dewatering Equipment

Sludge Dewatering Equipment

Introduction

The SLG® + Multi-disc Screw Press Dewatering System is a high-performance sludge dewatering solution engineered and exclusively provided by Orege North America. The system combines Orege's patented SLG® (Solid-Liquid-Gas) sludge conditioning technology with a Multi-disc MDQ503 screw press to deliver efficient dewatering performance, enhanced solids capture, and reduced polymer consumption.

Designed as a compact, modular system, the SLG® integrates advanced sludge conditioning with low-speed screw press dewatering to provide stable, continuous operation. By conditioning the sludge upstream of polymer addition, the SLG® improves floc structure and dewaterability, enabling higher cake solids and improved filtrate quality through the screw press process.

The system is ideally suited for municipal and industrial applications requiring reliable, automated dewatering with minimal operator intervention. Its modular design supports rapid deployment, ease of integration into existing treatment processes, and consistent performance under variable influent conditions.

Application

The SLG® + Multi-disc Screw Press Dewatering System is suitable for municipal wastewater sludges, including waste activated sludge, primary sludge, and blended sludges, where reliable dewatering and improved solids capture are required.

The system is also applicable to a wide range of industrial sludge dewatering applications, including food and beverage, pulp and paper, chemical, pharmaceutical, and energy-related processes. It is particularly effective in facilities experiencing variable influent conditions, poor dewaterability, or high polymer consumption.

The modular, containerized design allows the system to be deployed for temporary, supplemental, or long-term dewatering applications with minimal site preparation, enabling rapid integration into existing treatment processes while maintaining consistent, automated performance.

Working principle

The SLG® + SP MDQ503 Dewatering System operates by conditioning the feed sludge using Orege's patented SLG® (Solid-Liquid-Gas) technology prior to polymer addition. The SLG® applies controlled pressure, air, and velocity changes to restructure the sludge matrix, increasing available surface area and significantly improving polymer reaction efficiency. Following SLG® conditioning, polymer is injected to promote rapid and uniform flocculation, forming strong, shear-resistant flocs optimized for mechanical dewatering.

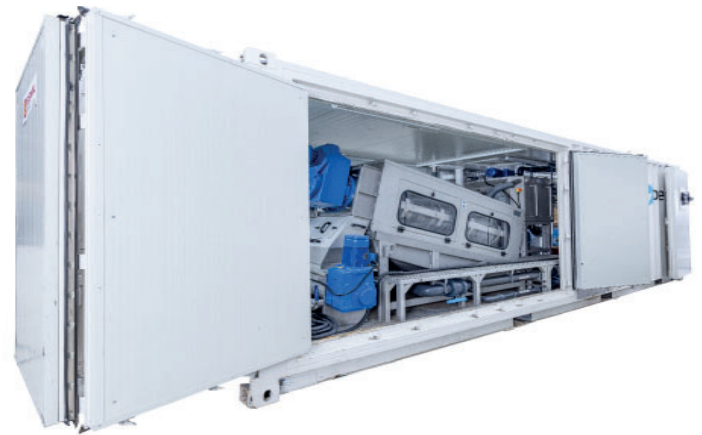

The flocculated sludge then passes through a deaeration stage to release excess air and entrained gases, ensuring stable downstream performance. The flocculated sludge is then fed to the feed tank of the MDQ-503 Multi-Disc Screw Press and flows via gravity into the MDQ-503 screws. As the sludge advances through the low-speed screw, increasing pressure and back pressure at the outlet zone compress the flocculated solids, achieving efficient water separation. Filtrate is discharged through the multi-disc filtration system, while dewatered sludge cake is conveyed and discharged at the end of the press. This integrated process maximizes solids capture, improves cake dryness, and reduces polymer consumption while maintaining stable, continuous operation under varying influent conditions.

Benefits

- Improved cake dry solids through advanced SLG® conditioning
- Reduced polymer consumption
- Higher throughput and solids loading
- Improved solids capture and filtrate quality
- Stable operation across varying sludge conditions
- Low maintenance requirements
- Fully integrated, turnkey rental solution
- No customer capital investment or spare parts responsibility

Features

- Patented SLG® sludge conditioning technology
- MDQ-503 Multidisc Screw Press
- Direct-injection polymer preparation and dosing system
- Integrated compressed air system and deaeration stage
- VFD-controlled feed and auxiliary equipment
- Integrated control panel
- Fully containerized, mobile design

Features description

SLG® sludge conditioning system

- Patented, in-line conditioning technology utilizing pressure, air, and velocity changes
- Restructures the sludge matrix prior to polymer addition
- Improves polymer effectiveness and reduces overall polymer consumption

Polymer injection and flocculation

- Direct-injection emulsion polymer preparation and dosing system
- Rapid, controlled flocculation following SLG® conditioning
- Optimized floc structure for enhanced gravity drainage and pressure dewatering

Deaeration stage

- Downstream deaeration to release excess air and entrained gases and stabilize the flocculated sludge prior to entering the feed tank.
- Improves drainage efficiency and operating consistency

Dewatering

- Sludge feed to the MDQ-503 Multi-Disc Screw Press
- Progressive thickening and dewatering through low-speed screw compression and backpressure control
- Optimized filtrate separation through multi-disc filtration prior to final cake discharge

Integrated controls and utilities

- Centralized control panel for SLG®, ancillary equipment, and MDQ-503 Multi-Disc Screw Press
- VFD-controlled feed & thickened sludge pumping and auxiliary systems

Dimensions

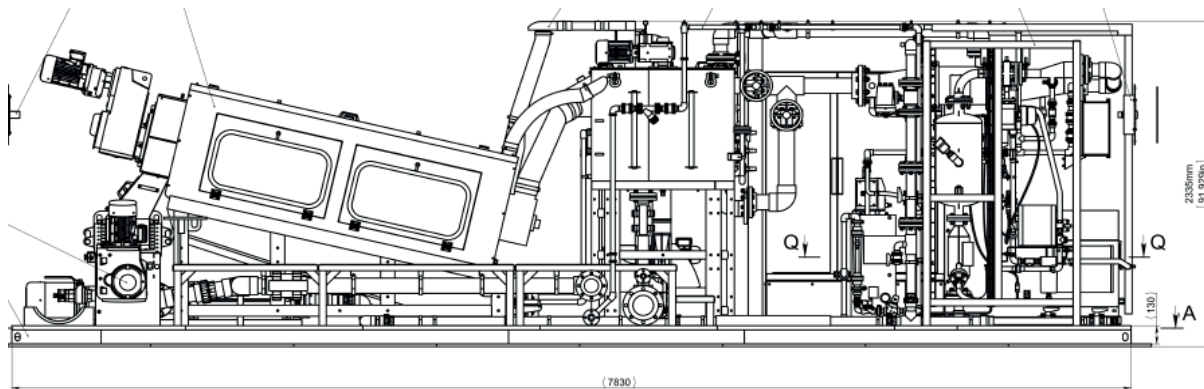

Model	SLG+SP MDQ 503 Container
Design Flow Rate @ 3% Aerobically Stabilized	88 gpm [20 m³/hr]
Solids Capacity Range	0.8-7.0% [8-70 g/l]
Maximum Mass Capacity @ 3% Aerobically stabilized	1,320 lb/hr @3% [599 kg/hr @30g/l]
Typical Dewatering Results	WAS: 15-17% 60%VS Primary: 18-20% Blended: 17-19%
Typical Polymer Treatment Rate Range	10-35 lb/DT [6.8 - 15.8 kg/DT] Active WAS
Container Overall Length & Width	323.43"x96.3" [8,215 x 2,445mm]
Container Overall Height	102.156" [2595mm]
Weight	~28,660 [13,000 kg]
Power	460v 3ø 100A 60hz, plug or direct wire
Feed Sludge Connection	4" Male Camlock or 4" Flange [DN100]
Filtrate Connection	4" Male Camlock or 8" Flange [DN200]
Polymer Feed Water Connection Potable	1.5" [DN40] Pot. Water 1800-3200 GPH [6.8-12.1 m³/hr], 25-50 psi [1.72-3.44 bar]
Wash Water Connection Reuse	2" [DN50] Reuse Water 4,800 GPH [18.17 m³/hr], 15-100 psi [1-6.9 bar]

Dewatering performance, including cake dry solids, throughput, and polymer consumption, is influenced by sludge characteristics and site-specific operating conditions; Orege works collaboratively with each client to optimize system performance throughout the rental period.